

FRC-N

Compensating
Jaw chuck

Lever chuck Ø 215 - 365 mm

- compensating rigid jaws
- spring loaded or fixed center
- proofline® chucks = fully sealed – low maintenance

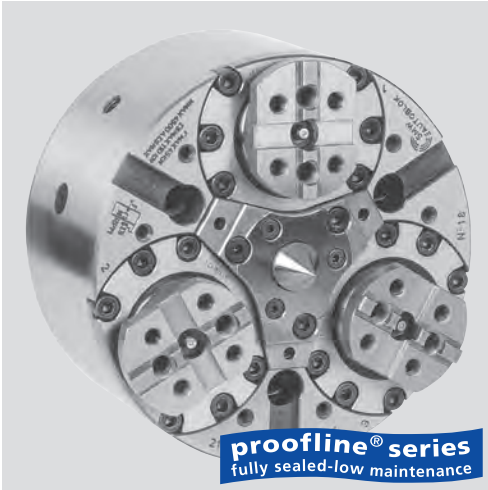

Application/customer benefits

- Compensating clamping of shafts between centers, where the clamping diameter is not concentric to the workpiece axis
- The workpiece is clamped compensating
- The grip force of the chuck supplies the torque necessary to machine the workpiece and pulls it down to the axial datum (center point/axial stop).
- Due to its high rigidity against torsion the chuck is ideal for turning as well as for milling operations

Technical features

- for O.D. clamping only
- compensating clamping with large compensating stroke
- tongue & groove base jaws
- pull down
- permanent grease lubrication
- high rigidity against torsion
- center point adjustable
- **proofline® chucks** = fully sealed – low maintenance

Standard equipment

3-jaw-chuck without centering insert
Mounting bolts

Ordering example

Chuck FRC-N 215 A6

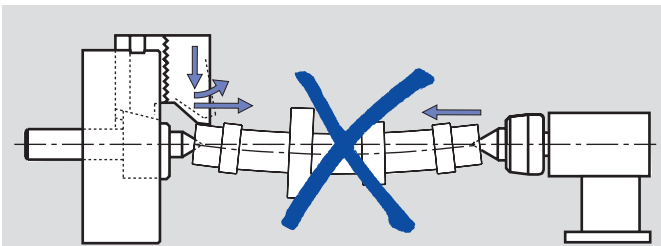

■ Non pull-down compensating chuck

Lifting of the top jaws pushes the shaft away from the centering reference; high tailstock force has to be used to overcome this lifting, resulting in a bending of the component

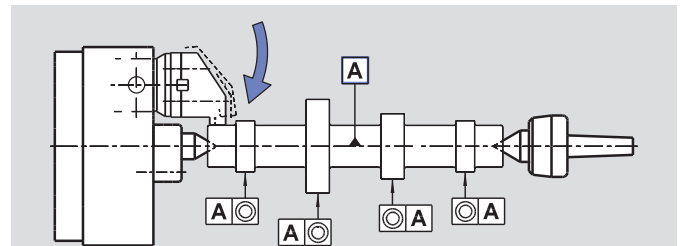

■ FRC-N pull-down and compensating clamping

The tailstock supplies the requested force to support the part only. The result is a cylindrical finished shaft with concentric diameters. The chuck pulls the work piece down to the center point without bending the work piece

Technical data

SMW-AUTOBLOK Type		FRC-N 215	FRC-N 285	FRC-N 365
Angular jaw stroke	deg.	6°	6°	6°
Radial jaw stroke at distance h	mm	6.3	7.3	8.4
Wedge stroke	mm	22	26	31
Compensation (on the dia.) at distance h	mm	±1.5	±2	±2.5
Max. draw pull	kN	45	70	110
Max. gripping force at distance h	kN	100	150	240
Max. speed	r.p.m.	4500	3500	2500
Weight (plain back without top jaws)	kg	30	62	120
Moment of inertia (m·r ²)	kg·m ²	0.17	0.65	2
Standard fixed center	Id. No.	81732141	81732841	81733641
Standard spring loaded center	Id. No.	81722141	81722841	81723641
Recommended actuating cylinders		100 SIN-S 125 SIN-S	125 SIN-S 150 SIN-S	150 SIN-S 200 SIN-S

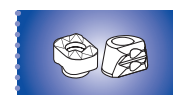

Page 310



Page 304

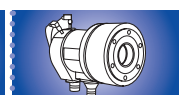

Page 217

Lever chuck Ø 215 - 365 mm

- compensating rigid jaws
- spring loaded or fixed center
- proofline® chucks = fully sealed – low maintenance

FRC-N

Compensating Jaw chuck

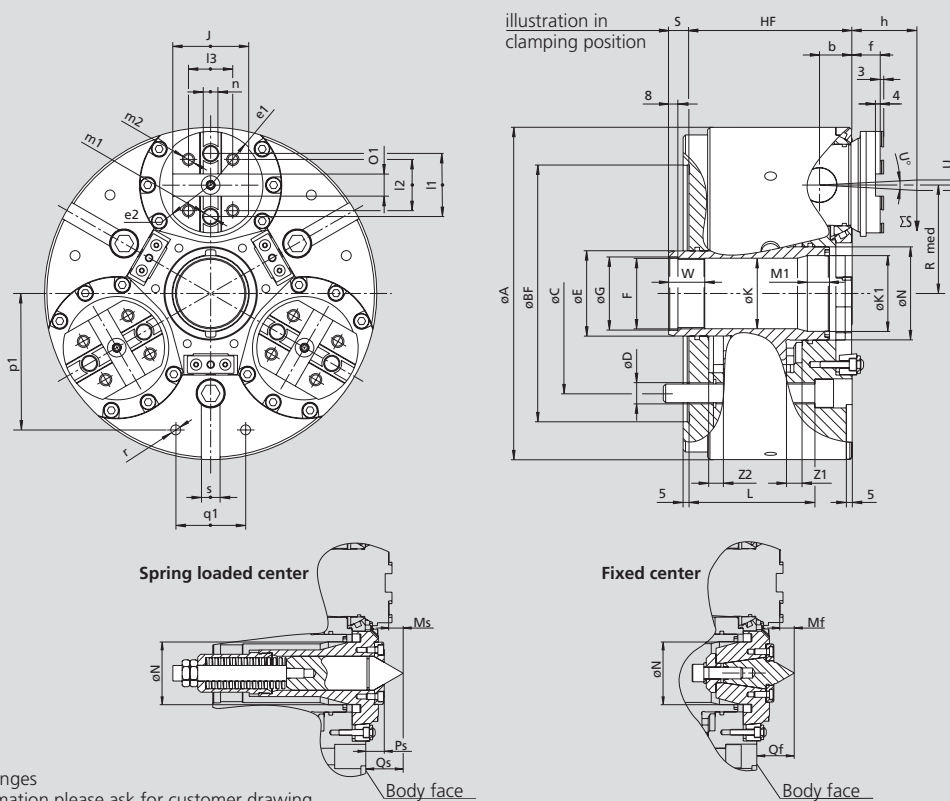

Subject to technical changes
For more detailed information please ask for customer drawing

SMW-AUTOBLOK	Type		FRC-N 215	FRC-N 285	FRC-N 365
	A	mm	215	285	365
	Bf	H6 mm	170	220	300
	C	mm	133.4	171.4	235
	D	mm	13.5	17	21
	E	mm	50	73	79
	F	mm	M42 x 1.5	M60 x 1.5	M68 x 2
	G	H8 mm	43	61	69
Through-hole	Hf	mm	120	140	168
	K	mm	40	60.5	60.5
	Ø K1/depth M1	mm	40	65/19	75/23.8
	L	mm	95	108	123
	N	H8 mm	52	80	90
	Mf	mm	14.5	14.6	21.7
	Qf	mm	32.5	38.6	42.7
	Ms	mm	13.8	14.4	19.9
	Ps	mm	21	19	21.5
	Qs	mm	31.8	38.4	40.9
	Rmed	mm	67	93	120
at middle stroke - clamping position	S	mm	15.4	17.5	24.8
min./max.	S	mm	4/26	4/30	9/40
Angular jaw movement	U°	deg.	6°	6°	6°
Radial stroke (1)	U	mm	6.3	7.3	8.4
	W	mm	30	31	30
	Z1	mm	11.4	13.5	15.8
	Z2	mm	10.6	12.5	15.2
	b	mm	22	28	34
	e1	mm	37.5	46	50
	e2	mm	33	41	50
	f	mm	18	24	21
Reference height	h	mm	38	42	46
	j	mm	55	65	70
	l1	mm	38	54	63.5
	l2	mm	32	44	48
	l3	mm	32	38	48
Thread/depth	m1	mm	M12/16	M16/20	M16/20
Thread/depth	m2	mm	M10/14	M12/19	M12/19
	n	h8 mm	7.94	12.7	12.7
	o1	H7 mm	12.68	19.03	19.03
	p1	mm	80	117	150
	q1	mm	45	60	80
Thread/depth	r	mm	M8/17	M10/19	M12/22
	s	H8 mm	16	16	20

(1) Calculated at **h** distance from the chuck's face (where normally the clamping takes place)